

# Template for 3 3/4" & 5" Backset 6K, 7KC, 8K and 9K Cylindrical Locks with RQE

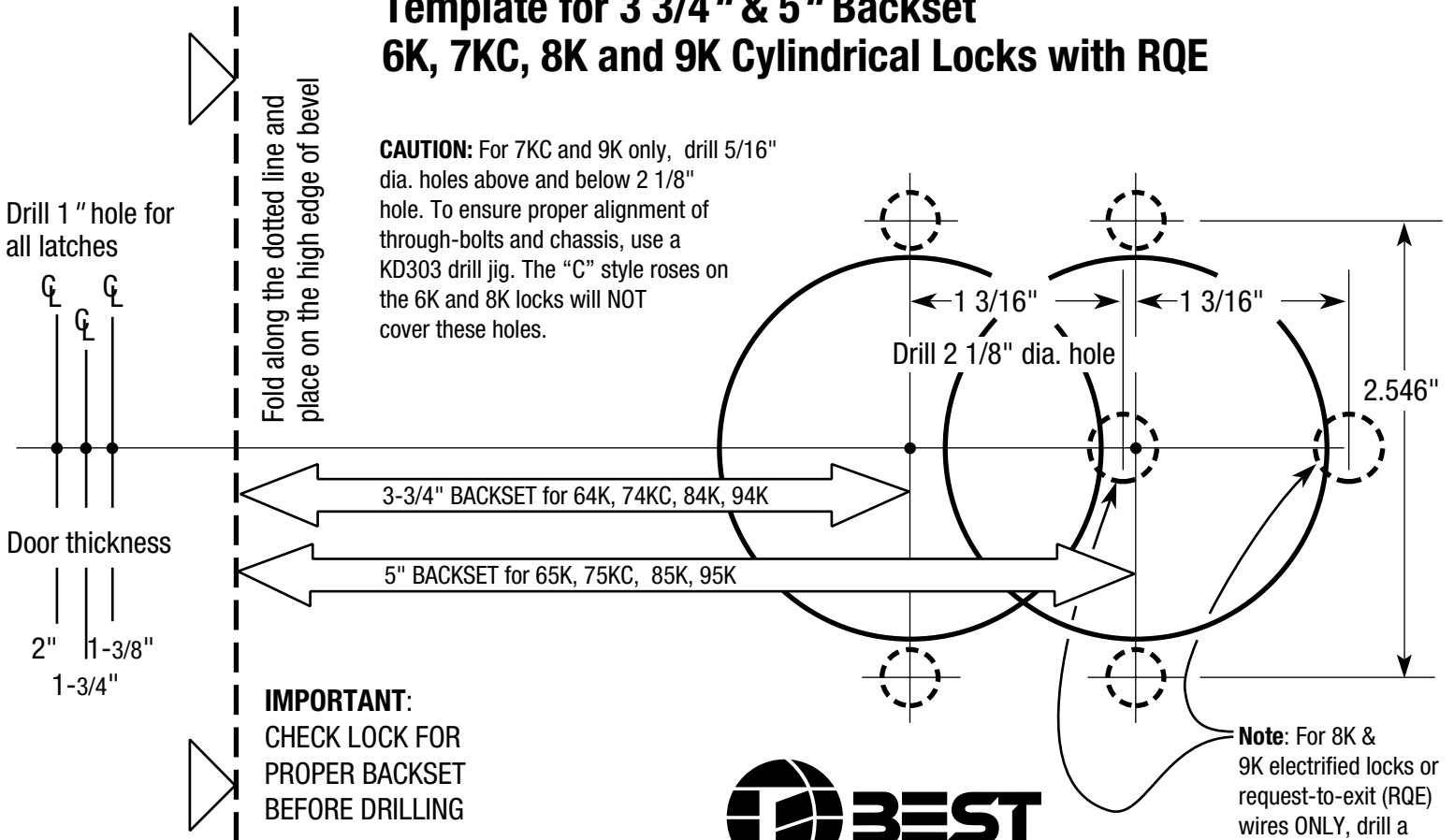

**CAUTION:** For 7KC and 9K only, drill 5/16" dia. holes above and below 2 1/8" hole. To ensure proper alignment of through-bolts and chassis, use a KD303 drill jig. The "C" style roses on the 6K and 8K locks will NOT cover these holes.

Fold along the dotted line and place on the high edge of bevel

Drill 1" hole for all latches

Door thickness

2"  
1-3/8"  
1-3/4"

3-3/4" BACKSET for 64K, 74KC, 84K, 94K

5" BACKSET for 65K, 75KC, 85K, 95K

Drill 2 1/8" dia. hole

1 3/16"

1 3/16"

2.546"

**IMPORTANT:**  
CHECK LOCK FOR  
PROPER BACKSET  
BEFORE DRILLING

**Note:** For 8K & 9K electrified locks or request-to-exit (RQE) wires ONLY, drill a 3/8" dia. hole as shown.

